

### 5.3.1 TECHNICAL DATA

**MAX OPERATING PRESSURE (PS):**

(carbon steel) 100 – 160 – 210 – 250 – 350 bar  
 (stainless steel) 100 bar (other, upon request)

**PRESSURE TEST (PT):** 1,43 x PS

**NOMINAL CAPACITIES: litres**

0.075 - 0.16 - 0.25 - 0.32 - 0.5 - 0.75 - 1 - 1.4 - 2 - 2.8 - 3.5

**WORKING TEMPERATURE:** -40 ÷ +80 °C

**COMPRESSION RATIO (Po : P2):** max 1 : 8; see Tab.5.3e

**FLUID VISCOSITY RANGE:** 10 ÷ 400 cSt

**RECOMMENDED VISCOSITY:** 36 cSt

**FLUID CONTAMINATION DEGREE:**

class 21/19/16 according to ISO 4406/99

**BODY MATERIAL:** - carbon steel shell painted with a black rust inhibitor coat  
 - stainless steel AISI 316L

**FILLING VALVE MATERIAL (internal screw):**

- galvanized carbon steel in compliance with Directive 2002/95/CE (RoHS) to resist to corrosion  
 - stainless steel AISI 316L

**DIAPHRAGM MATERIAL:**

- P = Nitrile rubber (NBR)  
 - Y = Epichlorohydrin (ECO)

See Table 5.3c and /or Chapter 1.5

**FILLING VALVE CONNECTION:** - M28 x 1.5  
 - without and closed

**FLUID PORT CONNECTION:** - internal thread:  
 1/2" - 3/4" BSP ISO228  
 - external thread: M33x1.5  
 M45x1.5

See Table 5.3e

**FLOW RATE:** see Table 5.3e

**WEIGHT:** see Table 5.3e

### 5.3.2 "AMS" DIAPHRAGM ADVANTAGES

- high compression ratio
- dirt tolerant
- light weight
- compact
- simple construction
- quick response
- permanently sealed for maintenance free operation
- works well on low lubricity fluids
- quick, easy installation and replacement
- can be mounted in any position
- long service life
- low cost



5.2a

### 5.3.3 HYDRAULIC SYMBOL

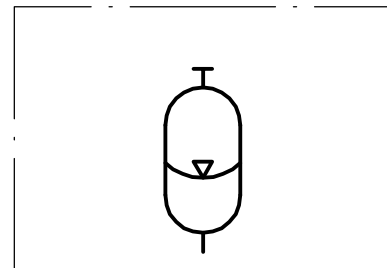

5.2b

### 5.3.4 DESCRIPTION

The welded type diaphragm accumulators cannot be repaired, as they are specially designed for high quantity and economical applications, where it is more practical to replace the unit rather than refurbishing it. These accumulators consist of a shell manufactured with a high strength alloy steel and a welded electron-beam.

The flexible diaphragm provides excellent gas and fluid separation. Diaphragm are available in two compounds:

- "P" nitrile (NBR)
- "Y" hydrin (ECO)

The button closes the fluid port when the accumulator is fully discharged to prevent diaphragm extrusion.

The fluid port is available provided with two types of connections:

- "G" BSP UNI228 female
- "W" BSP UNI228 female and external metric male

The gas valve is available in two versions:

- "VT" fixed pre-charge
- "VM" metric M28x1.5 gas valve and leak-free. It offers flexibility of checking or charging the accumulator (see charging kit type PCM).

This rugged gas valve features an internal hexagonal locking screw with sealing washer.

Diaphragm accumulators type AMS are then preferably used as shock absorbers and pulsation dampeners in the following sectors: industrial, machine tools, furniture and agriculture.

Compared to other accumulator types, the diaphragm ones have the highest energy density (energy content / mass). This feature is due to the spherical shape of the accumulator shell.

For the diaphragm accumulators, you can choose any type of installation. The preferred assembly is, however, the vertical one.

### 5.3.5 DIAPHRAGM - TEMPERATURE - LIQUID COMPATIBILITY

When selecting the accumulator variant, pay attention to the following non-binding notes with regard to hydraulic fluid, diaphragm material and the permissive temperature range.

Code letter	Polymer	ISO	Temperature range (°C)	Some of the liquids compatible with the polymer
<b>P</b>	Standard nitrile (Perburan)	NBR	-20 ÷ +80	Idrocarburi alifatici (propano, butano, benzina, olii, grassi minerali, carburante diesel, olio combustibile, kerosene), grassi ed olii minerali, fluidi HFA - HFB - HFC, molti acidi diluiti, alcali, soluzioni saline, acqua, acqua glicole
<b>Y</b>	Epichloridrin	ECO	-30 ÷ +110	Mineral oils and greases, aliphatic hydrocarbons (propane, butane and gasoline), silicone oils and greases, water at room temperature, resistance to ozone, aging and weathering.

For other hydraulic fluid and/or temperatures, please consult us.

5.3c

## 5.3.6 ORDER CODE

1 2 3 4 5 6 7 8 9 10  
**AMS 1 P 210 C G 4 VM - 0 / 30**

<b>1</b>	<b>Series</b>
Diaphragm accumulator = <b>AMS</b>	

<b>2</b>	<b>Nominal capacity</b>
	0,075 lt = <b>0,075</b>
	0,16 lt = <b>0,16</b>
	0,32 lt = <b>0,32</b>
	0,5 lt = <b>0,5</b>
	0,75 lt = <b>0,75</b>
	1 lt = <b>1</b>
	1,4 lt = <b>1,4</b>
	2 lt = <b>2</b>
	2,8 lt = <b>2,8</b>
	3,5 lt = <b>3,5</b>

<b>3</b>	<b>Diaphragm material</b>
Gomma nitrilica (NBR)	= <b>P</b>
Epicloridrina (ECO)	= <b>Y</b>

<b>4</b>	<b>Max working pressure (PS)</b>		
Capacity (litres)	Carbon steel (bar)	Stainless steel	
0,075 =	<b>250</b>	<b>100</b>	
0,16 =	<b>250</b>	<b>100</b>	
0,32 =	<b>210</b>	<b>100</b>	
0,5 =	<b>210</b>	<b>100</b>	
0,75 =	<b>150 - 210 - 330</b>	<b>100</b>	
1 =	<b>210</b>	<b>100</b>	
1,4 =	<b>210 - 250 - 350</b>	<b>100</b>	
2 =	<b>100 - 250</b>	<b>100</b>	
2,8 =	<b>250 - 350</b>	<b>100</b>	
3,5 =	<b>250 - 350</b>	<b>-</b>	

Special variants on request

### Types normally available from stock:

- AMS0.32P210CG4-0-VM/30
- AMS0.5P210CG4-0-VM/30
- AMS0.75P210CG4-0-VM/30

<b>10</b>	<b>Precharge pressure (bar)</b>
Standard 30 bar = <b>0 ÷ 130</b> (max 130 bar)	

<b>9</b>	<b>Test and certification</b>
Factory testing	= <b>0</b>
TR (Russia)	= <b>1</b>
ML (China)	= <b>3</b>
PED97/23/EC(for capacity 1,5-2,5 l)	= <b>8</b>
ATEX 94/9EC	= <b>9</b>
RTN Passport (Russia)	= <b>11</b>
Algeria passport	= <b>12</b>
Standard regulation (NR13) (Brazil)	= <b>13</b>
Tunisia passport	= <b>14</b>

<b>8</b>	<b>Gas side connection</b>
Standard filling valve thread M28x1.5	= <b>VM</b>
Without pre-charge valve with fixed pre-charge calibration	= <b>VT</b>

<b>7</b>	<b>Dimension of connection side</b>
For the type of connection:	
G (for capacity 0.075 ÷ 2 l) 1/2"	= <b>4</b>
G (for capacity 2 ÷ 3.5 l) 3/4"	= <b>5</b>

<b>6</b>	<b>Fluid port connection</b>
BSP ISO 228 Female	= <b>G</b>
BSP ISO 228 Female and metric male	= <b>W</b>
male M33x1.5 for capacity 0.5-0.75-1-1.4 - 2 l	
male M45x1.5 for capacity 2.8 -3.5	

<b>5</b>	<b>Body material</b>
Carbon steel	= <b>C</b>
Stainless steel (100 bar)	= <b>X</b>

## 5.3.7 DIMENSIONS

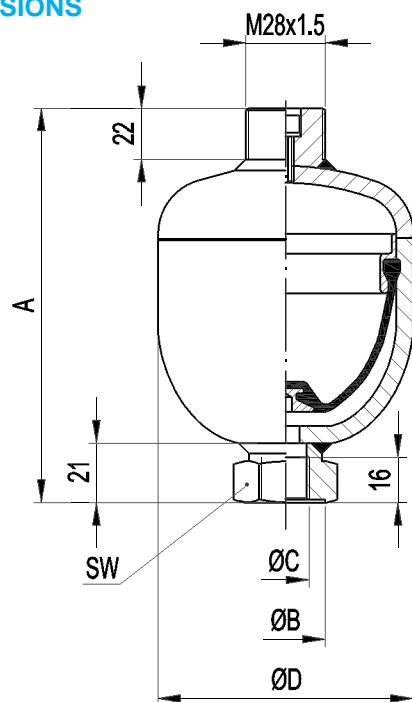

fig. I

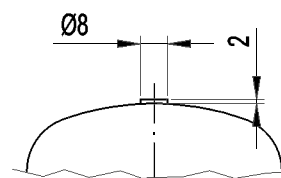

Fig. II

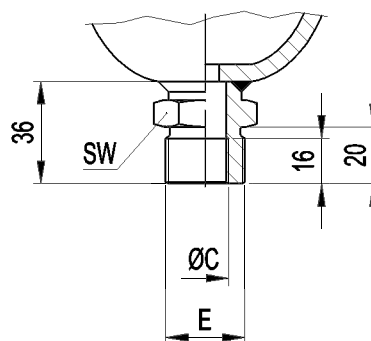

fig. II

5.3d

Accumulator type AMS	Fig.	Nominal gas value litres	Actual gas value litres	Working pressure bar	PED category for the liquids of group 2	Maximum differential pressure* bar	Flow rate** l/min	Maximum compression ratio Po/P2	A mm	Ø B mm	Ø C mm	Ø D mm	E mm	SW mm	Dry weight Kg
AMS 0,075	I- II	0,075	0,075	250	Art.3 (3)	210	20	1 : 8	111	29	1/2"	64	-	32	0,7
AMS 0,16	I- II	0,16	0,16	250	Art.3 (3)	210	20	1 : 8	120	29	1/2"	75	-	32	1
AMS 0,32	I- II	0,32	0,32	210	Art.3 (3)	140	40	1 : 8	140	29	1/2"	93	-	32	1,4
AMS 0,5	I-II-III	0,5	0,5	210	Art.3 (3)	175	50	1 : 8	152	34	1/2"	106	M33x1,5	41	2
AMS 0,75	II-III	0,75	0,75	150	Art.3 (3)	120	50	1 : 8	166	34	1/2"	121	M33x1,5	41	2,6
	210			175		122			2,6						
	330			150		125			4,4						
AMS 1	I-II-III	1	1	210	Art.3 (3)	170	50	1 : 8	180	34	1/2"	136	M33x1,5	41	3,5
AMS 1,4	I-II-III	1,4	1,4	140	I	100	50	1 : 8	199	34	1/2"	150	M33x1,5	41	4,2
				250		120			148			5,4			
				350		150			160			7,4			
AMS 2	I-II-III	2	2	100	I	80	50	1 : 8	213	34	1/2"	163	M33x1,5	41	3,5
				210		120			144			4,2			
				250		140			155			7,5			
				350		200			180			11,3			
AMS 2,8	I-II-III	2,8	2,8	210	II	100	50	1 : 4	213	34	1/2"	163	M33x1,5	41	8,2
				250		140			174			10			
				350		200			180			14,3			
AMS 3,5	I-II	3,5	3,5	250	II	140	70	1 : 4	307	34	3/4"	174	-	41	11
				350		200			180			16			

\* The maximum differential pressure is the maximum allowable difference between the maximum pressure and the minimum working pressure (P2-P1) to have an infinite life cycle of the accumulator (greater than 2,000,000 cycles).

\*\* Flow rate measured using mineral oil with viscosity of 36 cSt at 50°C and  $\Delta P = 5$  bar

5.3e

### 5.3.8 EUROPE MARKET

All hydraulic accumulators are pressure vessels and are subject to the national regulations and directives, valid at the place of installation. Diaphragm accumulator type AMS, up to and including 1 litre, must not be CE marked.

For diaphragm accumulator type AMS, greater than 1 litre, every shipping batch is provided with a conformity declaration and use and maintenance instructions and/or all documents requested.

All vessel categories (see Table 5.3e) must be protected by means of a pressure relief valve in accordance with Directive 97/23/EC.

### 5.3.9 SPARE PARTS CODE

Item	Description	AMS 0.075 ÷ 2,8
1	Gas valve VM	V2220-CP

5.2f

### 5.3.10 ACCESSORIES

For clamps, see Cap.7

For pre-loading and charging set, see Cap.11.2

For pulse damper adapters, see Cap.12.1

### 5.3.11 COMMISSIONING AND MAINTENANCE

#### Delivery condition

Diaphragm accumulators are delivered pre-charged with nitrogen at a pressure of 30 bar or at value of pressure required at time of order.

The pre-charge value is still on the nameplate of the accumulator.

Depending on the size and quantity ordered, the diaphragm accumulators are shipped in boxes or in cartons or on pallets, or wooden boxes on request.

Unless otherwise required, certificates and documentation are provided together with the accumulators.

#### Handling

The original packaging is suitable for handling and general storage.

Where necessary, you should use suitable lifting equipment to support the weight of the accumulators.

Protect from impact, however, the packaging and handle it with care.

#### Storage

During storage in the warehouse, leave the product in its original packaging, keeping it away from heat sources and naked flames. The storage temperature should be between +10 and +40°C.

After six years of storage, it is essential to proceed with the replacement of all elastomeric parts before the commissioning.

#### Marking on the nameplate of the accumulator

With reference to the PED 97/23/EC classification, Article 3, Paragraph 3 and / or risk categories I or II according to the amount and maximum working pressure, the accumulator indicates the following

- logo, name and country of the manufacturer
- product code
- Month / year of production
- Serial number

- Maximum PS pressure and PT test pressure in bar
- Min. and max. TS working temperature in Celsius
- Volume V in litres
- Group of fluids allowed (II)
- CE marking (by volume exceeding 1 litre) with the identification number of the notified body
- Pre-charge pressure in bar

#### It is strictly forbidden to:

- engrave or permanently stamp the surfaces of the accumulator shell and / or carry out other operations that could affect or change the mechanical properties of the accumulator
- use the accumulator as a structural element: it should not be subjected to stresses or loads
- change the data of the nameplate and / or accumulator without the permission of the manufacturer
- use a (dangerous) fluid of Group 1 with equipment designed and manufactured for fluids of Group 2.

#### Installation

Before installation, you must perform a visual check to verify that the accumulator has not suffered any damage during shipping / handling. Verify that the requested type matches with what stamped on the nameplate.

We recommend using the accumulator with a suitable safety valve (see section 8) or a security safety block type BS (see section 9). This device provides user and equipment protection against possible damage caused by pressure surges, and also makes the maintenance of the accumulator easier, so facilitating the interception and the discharge.

Provide for a clearance of 200 mm above the gas pre-charge valve to allow access to and control of the pre-charge equipment (see section 11.2).

The accumulators type AMS may be installed in any position from horizontal to vertical (preferably with the pre-charge valve at the top), and the nameplate must be visible.

Proceed to the assembly so that no abnormal force affects the pipes connected directly or indirectly to the accumulator, so we recommend the use of supporting components and also fastening (please see Chapter 7) to avoid the transmission of vibrations.

Make sure the fluid is compatible with the elastomer of the diaphragm. Check that the max. allowed accumulator pressure is equal to or greater than that of the hydraulic circuit and that the temperature during operation is maintained within the range expected.

Make sure the fluid does not contain contaminants and/or abrasive.

#### Pre-charge of nitrogen

Normally, the diaphragm accumulators are delivered pre-charged with pressurized gas. The pre-charge of gas can be controlled and / or adjusted before or after installation of the accumulator in the hydraulic circuit. For the pre-charge, use only industrial dry nitrogen with a purity of min. 99%. It is important to use the nitrogen from a cylinder equipped with a pressure reducing valve (see Chap.11.3). Use the EPE pre-charge and charging set type PCM to check the charging pressure Calculated Against the pressure, and adjust if necessary.

If the pre-charge pressure is lower than required, connect the inflation tube on one side and the other of the equipment. Connect it to the cylinder of nitrogen or to the pressure reducer. Slowly enter the nitrogen in the accumulator until reaching a pressure slightly higher than that